



## 2021 ILCA & US Sailing Singlehanded National Championship (O'Day / Hanley / Barrett Trophies)

### Organizing Authority (OA):

Norfolk Yacht and Country Club – Norfolk, VA  
Big Blue Sailing Academy at Old Dominion University  
Lower Chesapeake Laser Fleet 12  
**June 17-20, 2021**

## SAILING INSTRUCTIONS

(version 06-16-2021) – **Amended 06-17-2021 (changes in red)**

The notation '[DP]' in a rule means that the penalty for a breach of that rule may, at the discretion of the protest committee, be less than disqualification. The notation '[NP]' in a rule means that a boat may not protest another boat for breaking that rule. This is added to RRS 60.1(a).

### 1. RULES

- 1.1 The event is governed by the rules as defined in *The Racing Rules of Sailing* (RRS).
- 1.2 [DP] RRS 40.1 Personal Flotation Devices shall apply, with the additional requirement that each competitor shall wear a USCG approved life jacket that is 100% dependent on foam for flotation and the appropriate size for the sailor, at all times while on the water, except for brief periods while adding or removing clothing.
- 1.3 The ILCA 6 class is capped at 134 boats and will have two separate starts but will be scored as a single class for qualifying purposes and then split into gold and silver if a minimum of five races are completed.
- 1.4 [US Sailing Regulation 10](#) shall apply. A violation of this Instruction may be protested by race officials or a competitor; however an inadvertent and momentary breach of this instruction may receive a penalty less than disqualification at the discretion of the protest committee. This changes rule 64.1.
- 1.5 The US Sailing Prescription to RRS 32 shall apply.

### 2. CHANGES TO SAILING INSTRUCTIONS

Any changes to the SIs made on shore will be posted no later than 45 minutes before the first warning signal on the day in which it will take effect, except that any change to the schedule of races will be posted by 2000 on the day before it will take effect.

### 3. COMMUNICATIONS WITH COMPETITORS

- 3.1 Notices to competitors will be posted on the official notice board located on the event website:  
<https://theclubspot.com/regatta/RE55JpGbfE>
- 3.2 The race office is located at Old Dominion University Sailing Center.
- 3.3 On the water, RC intends to monitor and communicate over VHF ~~69~~ **71**.

#### 4. [DP] CODE OF CONDUCT

- 4.1 Competitors and support persons shall comply with reasonable requests from event officials. Reasonable actions/requests by event officials to implement COVID-19 guidance, protocols or legislation, even if they later prove to have been unnecessary, are not improper actions or omissions.
- 4.2 The [US Sailing Championships Code of Conduct](#) shall apply.

#### 5. SIGNALS MADE ASHORE

- 5.1 Signals made ashore will be displayed from the flagpole at the ODU Sailing Center.
- 5.2 When flag AP is displayed ashore, '1 minute' is replaced with 'not less than 45 minutes' in Race Signals AP.

#### 6. SCHEDULE OF RACES

##### 6.1

Day	Date	Time	Event
Thursday	June 17	0800	Venue Opens
		1400-1830	On-site check-in & sail inspection
		1900	Competitors' Meeting followed by Coaches' Meeting Zoom link: <a href="https://odu.zoom.us/j/91317530131">https://odu.zoom.us/j/91317530131</a> Dial-in by phone: +16465588656,,91317530131#
Friday	June 18	0800-0900	On-site check-in & sail inspection
		1030	First warning signal
Saturday	June 19	1030	First warning signal
Sunday	June 20	1030	First warning signal
		1500	No warning signal made after this time
		After racing	Awards to follow after the close of the protest deadline

- 6.2 No more than four races per class will be scheduled for each day.
- 6.3 The ILCA 6 class will sail a qualifying series followed by a final series as described in SI Attachment 1.

#### 7. CLASS FLAGS

- 7.1 ILCA 7: white flag with red ILCA logo
- 7.2 ILCA 6 yellow: green flag with red ILCA logo over a solid yellow flag
- 7.3 ILCA 6 blue: green flag with red ILCA logo over a solid blue flag
- 7.4 ILCA 4: yellow flag with red ILCA logo

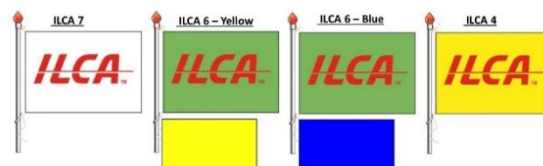

#### 8. RACING AREA

- 8.1 There are two racing areas at this venue. Area A is off the ODU Sailing Center in the Lafayette River. Area B is near Craney Island and Middle Ground Lighthouse and approximately 4nm from the Sailing Center.
- 8.2 While proceeding to race Area B, competitors shall be towed or escorted by the across the Elizabeth River shipping channel in proximity to G19. **There will be safety boats stationed at G19 and R18. Competitors are instructed to sail to the safety boat to be released across the channel. Unless crossing the channel, competitors must stay clear of the shipping lane and any commercial traffic. Location of dredge work may change the location of crossing so any and all changes will be noted by the race committee.**
- 8.3 Competitor launching will be from the ODU Sailing Center: 4551 Powhatan Ave, Norfolk, VA 23529



## 9. COURSES

9.1 The courses are described in SI Attachment 2.

9.2 The course to be sailed will be posted on a board on the RC Signal vessel at least 1 minute before the warning signal for that class.

## 10. MARKS

10.1

Mark	Original mark description	Change mark description
1, 2	Large orange cylinders	Large yellow cylinders
3s, 3p	Round orange tomatoes	
4s, 4p	Small yellow cylinders	

10.2 If a gate mark is missing at 3s/3p or 4s/4p, boats shall round the remaining single mark to port.

## 11. THE START

11.1 Races will be started using RRS 26.

11.2 The starting line is between staffs displaying orange flags on RC vessels at each end.

11.3 [DP] Boats whose warning signal has not been made shall avoid the starting area during the starting sequence for other races.

11.4 A boat that does not start within five (5) minutes after her starting signal will be scored Did Not Start without a hearing. This is added to RRS A5.1 and A5.2.

## 12. CHANGE OF THE NEXT LEG OF THE COURSE

12.1 The race committee may, without signals, make minor adjustments to change the direction of a leg, or the length of leg, or adjust the angle or width of the leeward gate, provided that no boat is sailing to the mark.

12.2 When signaled in accordance with RRS 33, the race committee will lay a new mark (or move the finishing line) and remove the original mark as soon as practicable. When in a subsequent change a new mark is replaced, it will be replaced by an original mark.

## 13. THE FINISH

13.1 The finishing line is between a staff displaying an orange flag on the RC finish vessel and the course side of a nearby round green tomato. This changes Race Signals **Blue** (finishing line) flag.

13.2 Flag A displayed with no sound while boats are finishing means "no more racing today".

## 14. PENALTY SYSTEM

14.1 RRS Appendix V shall apply.

14.2 RRS Appendix P will apply modified as follows:

- (a) RRS P2.1 is changed to state "When a boat is penalized under rule P1.2 her penalty shall be a Two-Turns Penalty under rule 44.2. If she fails to take it she shall be disqualified without a hearing."
- (b) RRS ~~P2.3~~ **P2.2** and P2.3 are deleted.

## 15. TIME LIMITS AND TARGET TIMES

15.1 The time limit for the first boat to finish in each class is 90 minutes.

15.2 The target time for races is 45-60 minutes. Failure to meet the target times will not be grounds for redress. This is added to RRS 62.1(a).

15.3 The finishing window is 30 minutes after the first boat sails the course and finishes. Boats failing to finish within the finishing window, and not subsequently retiring, penalized or given redress, will be scored Time Limit Expired (TLE) without a hearing. A boat scored TLE shall be scored points for the finishing place two more than the points scored by the last boat that finished within the finishing window but not worse than DNF. This is added to RRS 35, A5.1, A5.2 and A10. 16.4.

## 16. HEARING REQUESTS

16.1 The protest time limit is 60 minutes after the RC Signal vessel docks or the RC signals no more racing today, whichever is later. The time will be posted on the official notice board.

- 16.2 Hearing request forms are available in the vicinity of the race office.
- 16.3 Notices will be posted no later than 30 minutes after the protest time limit to inform competitors of hearings in which they are parties or named as witnesses. Hearings will be held at the ODU Sailing Center.

## 17. SCORING

- 17.1 The scoring system in RRS Appendix A will be used.
- 17.2 A maximum of eleven races, in total, are scheduled for the entire regatta.
- 17.3 When fewer than ~~six~~ **five** races have been completed, a boat's series score will be the total of her race scores. When ~~six~~ **five** or more races have been completed, a boat's series score will be the total of her race scores excluding her worst score. **This changes NOR 12.1.**
- 17.4 A minimum of three races in a class is required to be completed to constitute a series for that class.
- 17.5 The format for ILCA 6 qualifying and championship rounds as described in Attachment #1 will be used.

## 18. [DP] [NP] SAFETY REGULATIONS

- 18.1 At regatta check-in, each sailor will be given a hull decal that shall be always affixed to their hull. Prior to launching each day there will be volunteers on the ramp to scan sailors out using their affixed hull decals. A competitor who will not be racing that day shall notify a volunteer at the launch ramp.
- 18.2 Immediately upon returning to shore, but **not later than 30 minutes** after the RC signal vessel docks, **competitors shall check in** with a volunteer at the launching ramp indicating their return to shore.
- 18.3 A boat that retires from a race shall notify a Race Official at the first reasonable opportunity or an ODU Staff Member promptly after returning to shore. A boat that withdraws from a race or does not intend to start a scheduled race shall inform a Race Official at the first reasonable opportunity.
- 18.4 Boats retiring early are required to keep clear of the shipping channel at all times, unless crossing. Boats are required to cross the shipping channel at R18/G19. Impedance to commercial traffic shall result in DSQ from the event. Failure to stay outside of the shipping channel may result in DSQ from the event.
- 18.5 All boats shall carry all Safety Gear as required by ILCA Rules ~~including~~ **and have access to a suitable and dedicated tow line at all times while afloat.**
- 18.6 Any official or support vessel may assist any competitors in the case of an emergency and when code flag V (see Race Signals) is displayed.
- 18.7 There may be a yellow ball with a floating tether below the starting area to serve as a breakdown buoy.

## 19. [DP] REPLACEMENT OF EQUIPMENT

Substitution of damaged or lost equipment is not allowed unless authorized by a technical or race committee member which shall be made at the first reasonable opportunity, which may be after the race.

## 20. OFFICIAL VESSELS

Judge vessels may display a "Judge" or "J" flag.

## 21. [DP] [NP] SUPPORT TEAMS

- 21.1 All support persons shall stay a minimum of 100 yards outside areas where boats racing from the time of the preparatory signal for the first class to start until all classes have finished or retired or the RC signals a postponement, general recall, or abandonment. When boats are racing, no support vessel shall be in the area between the inner and outer trapezoid loops. This shall not apply if asked to assist by a race official or in the case of an emergency.
- 21.2 During registration support persons shall notify the OA of their boats and submit the names, class, and sail number of the competitor(s) they are supporting.
- 21.3 All support vessels are required to carry a VHF radio capable of transmitting and receiving normal channels, be ready to assist with safety if requested and monitor the RC working channel.
- 21.4 It is encouraged that all support vessel drivers and crews wear a PFD at all times except while changing or adjusting clothing or personal equipment.
- 21.5 All support vessels shall be equipped with a functioning engine safety cut-out device (kill switch) which shall remain attached to the driver at all times while the engine is running.

21.6 ~~The US Sailing Coaching and Support Boat Policy shall apply. This event is Grade 3. Support vessels are allowed for this event subject to restrictions specified in these SIs.~~ **Since this event is both the ILCA US National Championship and US Singlehanded Championship, the US Sailing Coaching and Support Boat Policy will not apply. This changes “Conditions for the US Singlehanded Championship”. Support vessels are allowed for this event subject to restrictions specified in these SIs.**

## 22. TRASH DISPOSAL

Trash and empty water bottles may be placed aboard support or race official vessels.

## 23. BERTHING

[DP] [NP] If assigned by the OA, boats shall be kept in their assigned places while in the boat yard.

## 24. PRIZES

24.1 Prizes will be given to the top 5 boats in each class: ILCA 7, ILCA 6, ILCA 4

24.2 Top ILCA 4 and ILCA 6 female

24.3 Top Master in each category for the ILCA 7 class

24.4 Top ILCA 7 junior who shall not have had their 18<sup>th</sup> birthday before the first day of racing.

24.5 US SAILING SINGLEHANDED CHAMPIONSHIPS:

George D. O’Day Trophy to the overall highest placing ILCA 7 male

Helen Willis Hanley Trophy to the highest placing ILCA 6 female

Peter J. Barrett Sportsmanship trophy may be awarded

US Sailing medals will be awarded to the top finishers in each class

Only US citizens or resident aliens throughout the Championship Final event may be declared the US National Champion in each class.

## 25. RISK STATEMENT

RRS 3 states: ‘The responsibility for a boat’s decision to participate in a race or to continue to race is hers alone.’ By participating in this event each competitor agrees and acknowledges that sailing is a potentially dangerous activity with inherent risks. These risks include strong winds and rough seas, sudden changes in weather, failure of equipment, boat handling errors, poor seamanship by other boats, loss of balance on an unstable platform and fatigue resulting in increased risk of injury. **Inherent in the sport of sailing is the risk of permanent, catastrophic injury or death by drowning, trauma, hypothermia or other causes.**

## 26. FURTHER INFORMATION

Big Blue Sailing Academy

Lower Chesapeake Bay ILCA Fleet 12 Fleet Captain: Britt Drake

Chief Judge/Umpire: Sandy Grosvenor

Principal Race Officer: Chip Till

NYCC Waterfront Director: Duffy Danish

ODU Sailing Center

[Regatta@bigbluesailingacademy.com](mailto:Regatta@bigbluesailingacademy.com)

[cbdrake111@yahoo.com](mailto:cbdrake111@yahoo.com)

[sandy@gromurph.org](mailto:sandy@gromurph.org)

[chiptill5351@gmail.com](mailto:chiptill5351@gmail.com)

860-884-3641

757-683-3387



# 2021 ILCA & US Sailing Singlehanded National Championship (O'Day / Hanley / Barrett Trophies) June 17-20, 2021

## SI Attachment 1 – ILCA 6 QUALIFYING and FINAL SERIES

### 1. Qualifying and Championship Format

- 1.1. There will be a qualifying round for the ILCA 6 class followed by a championship round.
- 1.2. The qualifying round will be used to split the fleet into approximately equal groups for the championship round. If there is an uneven number of boats in qualifying or championship rounds, yellow or gold respectively will have the higher number.
- 1.3. A minimum of five (5) races is required to complete the qualifying round. If five (5) races have not been completed by all ILCA 6 fleets before the start of the last day of the championship, all remaining races will be sailed in the qualifying round format.
- 1.4. Competitors shall only sail in their assigned fleet each day.
- 1.5. Boats that receive scoring abbreviations as defined in RRS Appendix A10 shall be scored points for the finishing place one more than the number of boats in the fleet she was racing. This change is added to RRS Appendix A5.2.

### 2. Procedure for fleet assignments

- 2.1. Day one: assignment to a fleet for the first day of racing will be a combination of random assignment and seeding by the ILCA and the OA.
- 2.2. Day two: the results of previous day seeded Y-B-B-Y, Y-B-B-Y, etc...
- 2.3. Day three: if still in qualifying round, day three will be seeded using the same method for day two.
- 2.4. If there is no racing the previous day, the previous day's fleet assignments will still apply unless five races have been completed, in which case the championship round will begin.
- 2.5. Fleet assignments in the qualifying round will be made by 2000 hours the previous evening they are to take place. No protest or scoring inquiry will change the fleet assignments if finalized after 1900 hours.
- 2.6. Fleet assignments for the championship round will not factor in any protests, scoring reviews or redress decisions unless they are decided before midnight the night before championship round racing.
- 2.7. Decisions on fleet assignments will be final and not be grounds for redress. This is added to RRS 62.1(a).

### 3. Championship Round

- 3.1. Gold and silver will race as single fleets.
- 3.2. Assignment to the gold and silver fleets will be based on a competitor's overall finishing position in the qualifying round.
- 3.3. Assignment to each fleet will be final for the entire championship round.
- 3.4. A boat's overall score for the regatta will be the boat's total score from the qualifying round plus her total score from the championship round ~~including her excluded~~ **excluding her worst** score(s) as described in the "Scoring" section of these SIs.

### 4. Identification

While racing, boats shall display a color identification indicator on their lower mast section as supplied by the OA that corresponds to their daily assigned fleet.

# 2021 ILCA & US Sailing Singlehanded National Championship (O'Day / Hanley / Barrett Trophies)

June 17-20, 2021

## SI Attachment 2 – COURSES

(for diagram purposes only – not to scale – actual marks may differ in shape, size and color)

### I

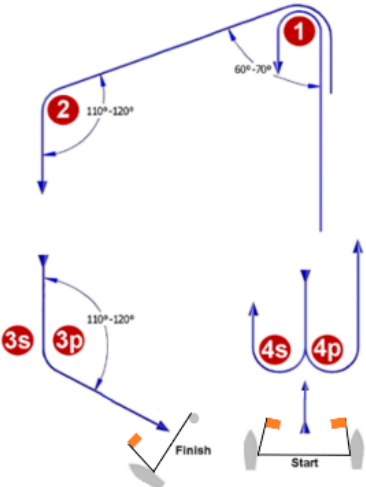

**Course: Inner Trapezoid**

Signal	Mark Rounding Order
I2	Start - 1 - 4s/4p - 1 - 2 - 3p - Finish
I3	Start - 1 - 4s/4p - 1 - 4s/4p - 1 - 2 - 3p - Finish
I4	Start - 1 - 4s/4p - 1 - 4s/4p - 1 - 4s/4p - 1 - 2 - 3p - Finish

### O

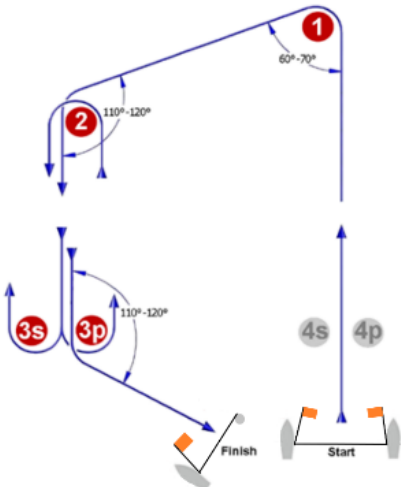

**Course: Outer Trapezoid**

Signal	Mark Rounding Order
O2	Start - 1 - 2 - 3s/3p - 2 - 3p - Finish
O3	Start - 1 - 2 - 3s/3p - 2 - 3s/3p - 2 - 3p - Finish
O4	Start - 1 - 2 - 3s/3p - 2 - 3s/3p - 2 - 3s/3p - 2 - 3p - Finish

### W

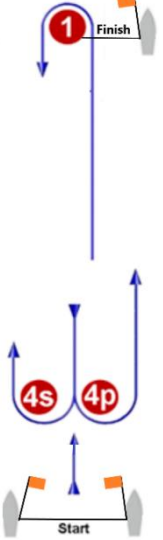

**Course: Windward/Leeward**

Signal	Mark Rounding Order
W2	Start - 1 - 4s/4p - Finish
W3	Start - 1 - 4s/4p - 1 - 4s/4p - Finish